

Description	Value
-------------	-------

General information:

Product name:	NBE 40-160/177 A-F2-A-BAQE
Product No:	98111258
EAN number:	5710629200808
Price:	On request

Technical:

Speed for pump data:	1450 rpm
Rated flow:	22.3 m ³ /h
Rated head:	10.1 m
Actual impeller diameter:	177 mm
Impeller nom:	160 mm
Primary shaft seal:	BAQE
Secondary shaft seal:	NONE
Shaft diameter:	24 mm
Curve tolerance:	ISO9906:2012 3B
Pump version:	A

Materials:

Pump housing:	Cast iron EN-GJL-250 ASTM A48-40 B
Impeller:	Cast iron EN-GJL-200 ASTM A48-30 B
Material code:	A

Installation:

Maximum ambient temperature:	50 °C
Maximum operating pressure:	16 bar
Flange standard:	EN 1092-2
Connect code:	F2
Pump inlet:	DN 65
Pump outlet:	DN 40
Pressure stage:	PN 16
Wear ring(s):	neckring(s)

Liquid:

Pumped liquid:	Water
Liquid temperature range:	0 .. 120 °C
Liquid temp:	20 °C
Density:	998.2 kg/m ³

Electrical data:

Motor type:	90SD
IE Efficiency class:	NA
Rated power - P2:	1.1 kW
Mains frequency:	50 Hz
Rated voltage:	3 x 380-500 V
Rated current:	2,30-2,10 A
Cos phi - power factor:	0,90-0,74
Rated speed:	180-2000 rpm
Efficiency:	87,2%
Number of poles:	4
Enclosure class (IEC 34-5):	IP55
Insulation class (IEC 85):	F
Motor protec:	YES
Motor No:	98190210
Mount. design. acc. IEC 34-7:	IM V1/B5

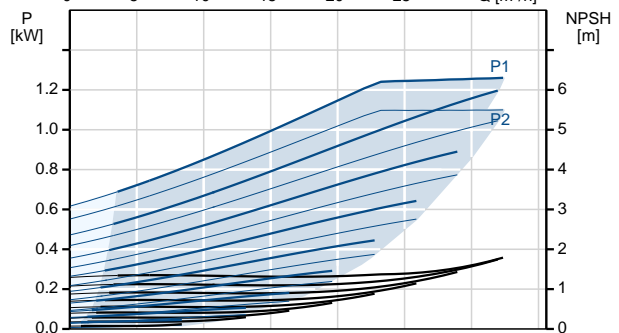
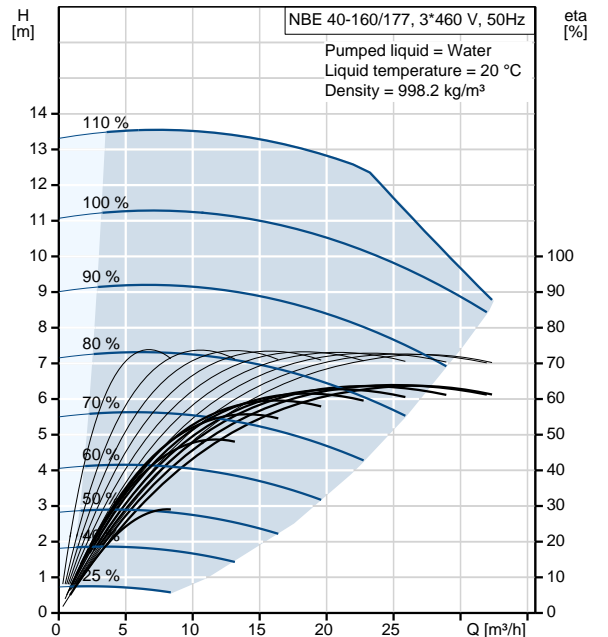



Company name:

Created by:

Phone:

Date:

10/11/2016

Description	Value
Lubricant type:	Grease
Controls:	
Control panel:	HMI200 - Standard
Function Module:	FM200 - Standard
Others:	
Label:	Grundfos Blueflux
Minimum efficiency index, MEI :	0.70
ErP status:	EuP Standalone/Prod.
Net weight:	43 kg
Gross weight:	62 kg
Shipping volume:	0.173 m ³
Config. file no:	98478703

98111258 NBE 40-160/177 50 Hz

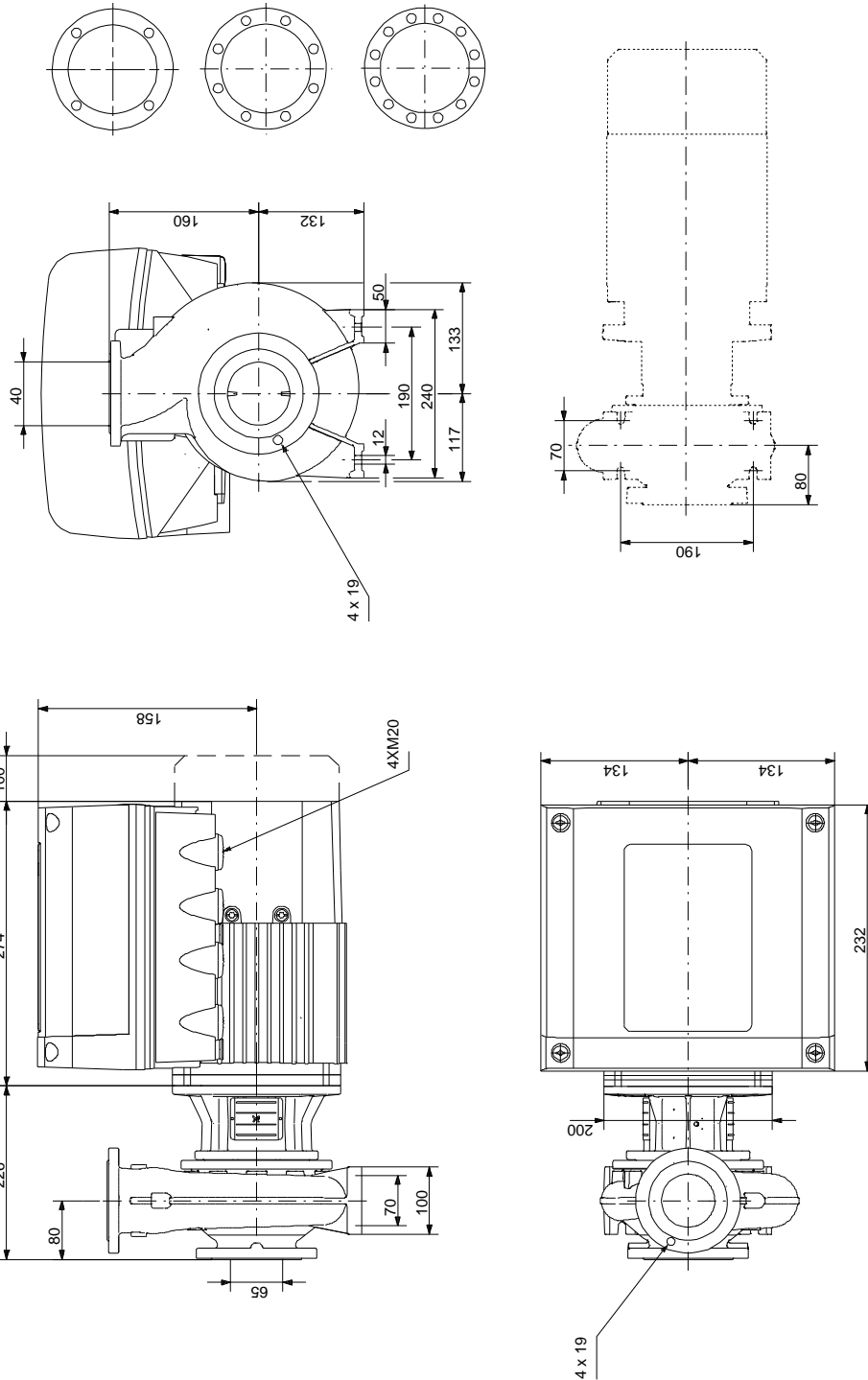

Note! All units are in [mm] unless others are stated.
 Disclaimer: This simplified dimensional drawing does not show all details.